





CHW 469 : Embedded Systems

Instructor:

Dr. Ahmed Shalaby <http://bu.edu.eg/staff/ahmedshalaby14#>

<https://piazza.com/fci.bu.edu.eg/spring2017/chw469/home>

Lab

| Remove Product(s) | | Qty. | Total |
|--------------------------|--|------|-----------|
| <input type="checkbox"/> |  | 1 | 10.00L.E. |
| <input type="checkbox"/> |  | 1 | 60.00L.E. |
| <input type="checkbox"/> |  | 1 | 7.50L.E. |
| <input type="checkbox"/> |  | 1 | 35.00L.E. |
| <input type="checkbox"/> |  | 1 | 48.00L.E. |

Assignment no. 2

In Banha-bank branch, It is proposed to install an embedded system to monitor the client queue in front of the tellers. One of the requirement, the system should indicate the availability of the tellers in order to allow the clients to enter the queue. The manager said “If there are no tellers the system shouldn't allow clients entrance and a red indicator alarm is ON. But if there is one teller or more, the system should accept the clients and the alarm is OFF, given that there are four tellers”. Your team leader asks you to provide the circuit to implement the required function.

Introduction to Embedded Systems

- **Cyber-Physical Systems** is another name for **embedded systems**, introduced in 2006 because these systems combine the intelligence of a computer with the physical objects of our world.
- **Component** is very **broad** including **software, hardware** - digital hardware, analog circuits, mechanical hardware, power supply and distribution, sensors, and actuators.
- **Behavior** is embodied by the responses of its **outputs to changes** in its **inputs**. Both **time and state** are important factors.
- **Microcontrollers** which are microcomputers incorporating the processor, RAM, ROM and I/O ports into a single package, are often employed in an embedded system because of their **low cost, small size,** and **low power requirements**.

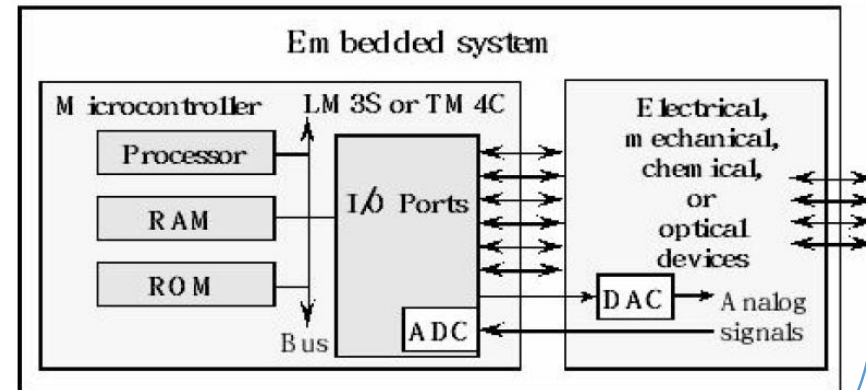

Good Enough Software, Soon Enough

- How do we make software *correct enough* without going bankrupt?
 - Need to be able to develop (and test) software efficiently
- Follow a good plan
 - Start with customer requirements
 - Design architectures to define the building blocks of the systems (tasks, modules, etc.)
 - Add missing requirements
 - Fault detection, management and logging
 - Real-time issues
 - Compliance to a firmware standards manual
 - Fail-safes

Good Enough Software, Soon Enough

- Follow a good plan (Cont...)
 - Create detailed design
 - Implement the code, following a good development process
 - Perform frequent design and code reviews
 - Perform frequent testing (unit and system testing, preferably automated)
 - Use revision control to manage changes
 - Perform post-mortems to improve development process

What happens when the plan meets reality?

- We want a robust plan which considers likely risks
 - What if the code turns out to be a lot more complex than we expected?
 - What if there is a bug in our code (or a library)?
 - What if the system doesn't have enough memory or throughput?
 - What if the system is too expensive?
 - What if the lead developer quits?
 - What if the lead developer is incompetent, lazy, or both (and *won't* quit!)?
 - What if the rest of the team gets sick?
 - What if the customer adds new requirements?
 - What if the customer wants the product two months early?
- Successful software engineering depends on balancing many factors, many of which are **non-technical!**

Risk Reduction

- Plan to the work to accommodate risks
- Identify likely risks up front
 - Historical problem areas
 - New implementation technologies
 - New product features
 - New product line
- Severity of risk is combination of likelihood and impact of failure

Software Lifecycle Concepts

- Coding is the most visible part of a software development process **but is not the only one**
- Before we can code, we must know
 - What **must the code do?** *Requirements specification*
 - How will the **code be structured?** *Design specification*
 - *(only at this point can we start writing code)*
- How will we know if the code works? **Test plan**
 - Best performed when defining requirements
- The software will likely be enhanced over time - **Extensive downstream modification and maintenance!**
 - Corrections, adaptations, enhancements & preventive maintenance

Product life Cycle

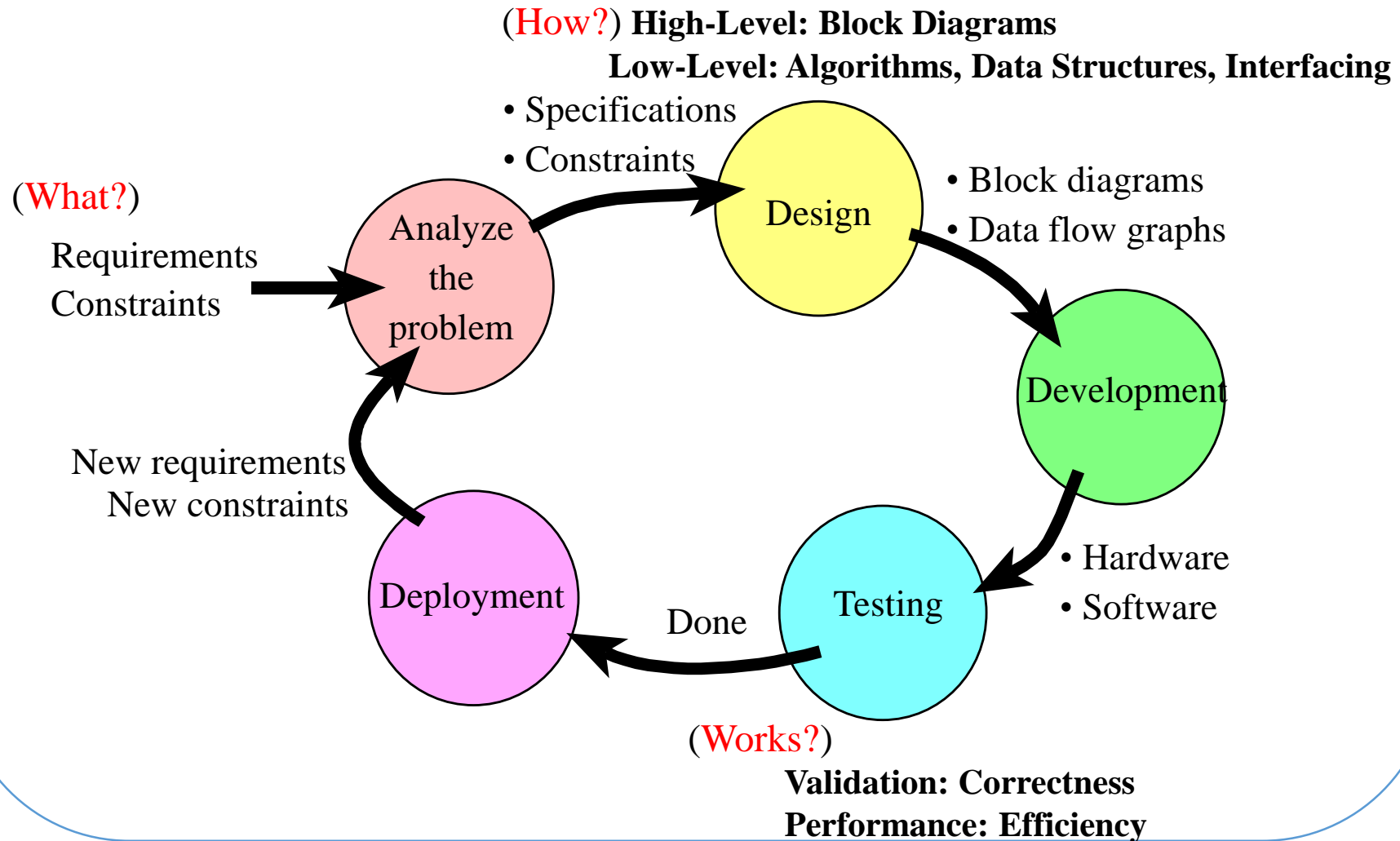

Product life Cycle (cont...)

- **Requirement:** a specific parameter that the system must satisfy.
(informal description of **what customer wants**)
- **Specifications:** detailed parameters describing how the system should work. (size, weight, position, etc...)
(precise description of **what design team should deliver**)
- **Constraint:** a limitation, within which the system must operate. (Cost).
- **Safety:** The risk to humans or the environment.
- **Accuracy:** The difference between the expected truth and the actual parameter.
- **Precision:** The number of distinguishable measurements.
- **Resolution:** The smallest change that can be reliably detected.
- **Response time:** The time between a triggering event and the resulting action.
- **Bandwidth:** The amount of information processed per time.

Product life Cycle (cont...)

- **Maintainability**: The flexibility with which the device can be modified.
- **Testability**: The ease with which proper operation of the device can be verified.
- **Compatibility**: The conformance of the device to existing standards.
- **Mean time between failure**: The reliability of the device, the life of a product.
- **Size and weight**: The physical space required by the system.
- **Power**: The amount of energy it takes to operate the system.
- **Unit cost**: The cost required to manufacture one additional product.
- **Time-to-prototype**: The time required to design, build, and test an example system.
- **Time-to-market**: The time required to deliver the product to the customer.
- **Human factors**: The degree to which our customers like/appreciate the product.

Design Before Coding

- Ganssle's reason #9: **Starting coding too soon**
- Underestimating the **complexity** of the needed software is a very common risk
- Writing code locks you in to specific implementations
 - Starting too early may paint you into a corner
- Benefits of **designing** system before **coding**
 - Get early insight into system's complexity, allowing more **accurate effort estimation** and scheduling
 - Can use design diagrams rather than code to discuss **what system should do and how**.
 - Can use design diagrams in documentation to **simplify code maintenance** and reduce risks of **staff turnover**

*Jack Ganssle is an internationally-recognized embedded systems engineer, author and speaker. See <http://www.ganssle.com/articles/jackstoptenlist.htm> for more on this.

Development Models



- How do we schedule these pieces?
- Consider amount of development risk
 - New MCU?
 - Exceptional requirements (throughput, power, safety certification, etc.)
 - New product?
 - New customer?
 - Changing requirements?
- Choose model based on risk
 - Low: Can create detailed plan. Big-up-front design, **waterfall**
 - High: Use iterative or agile development method, **spiral**. Prototype high-risk parts first

Waterfall (Idealized)

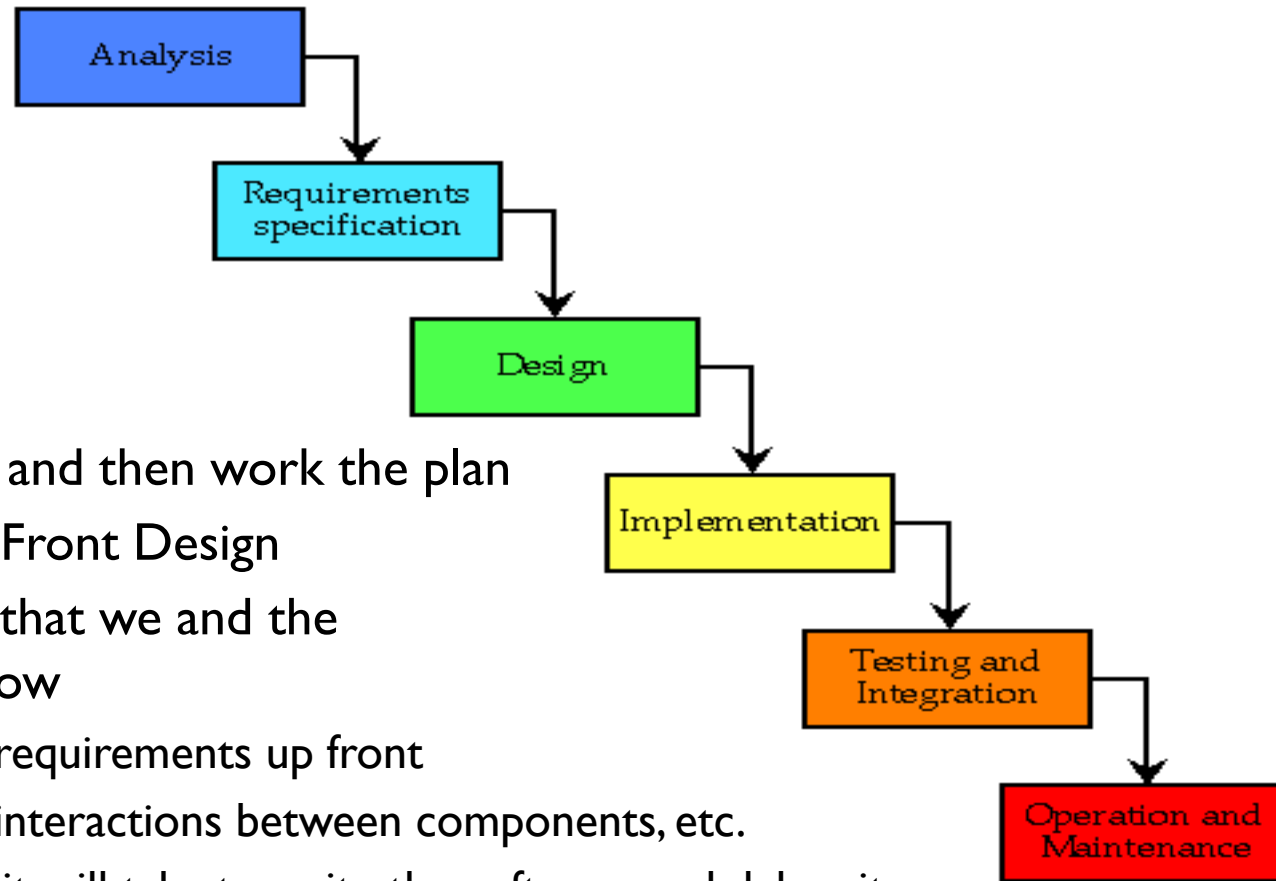

- Plan the work, and then work the plan
- BUFD: Big Up-Front Design
- Model implies that we and the customers know
 - All of the requirements up front
 - All of the interactions between components, etc.
 - How long it will take to write the software and debug it

Waterfall (As Implemented)

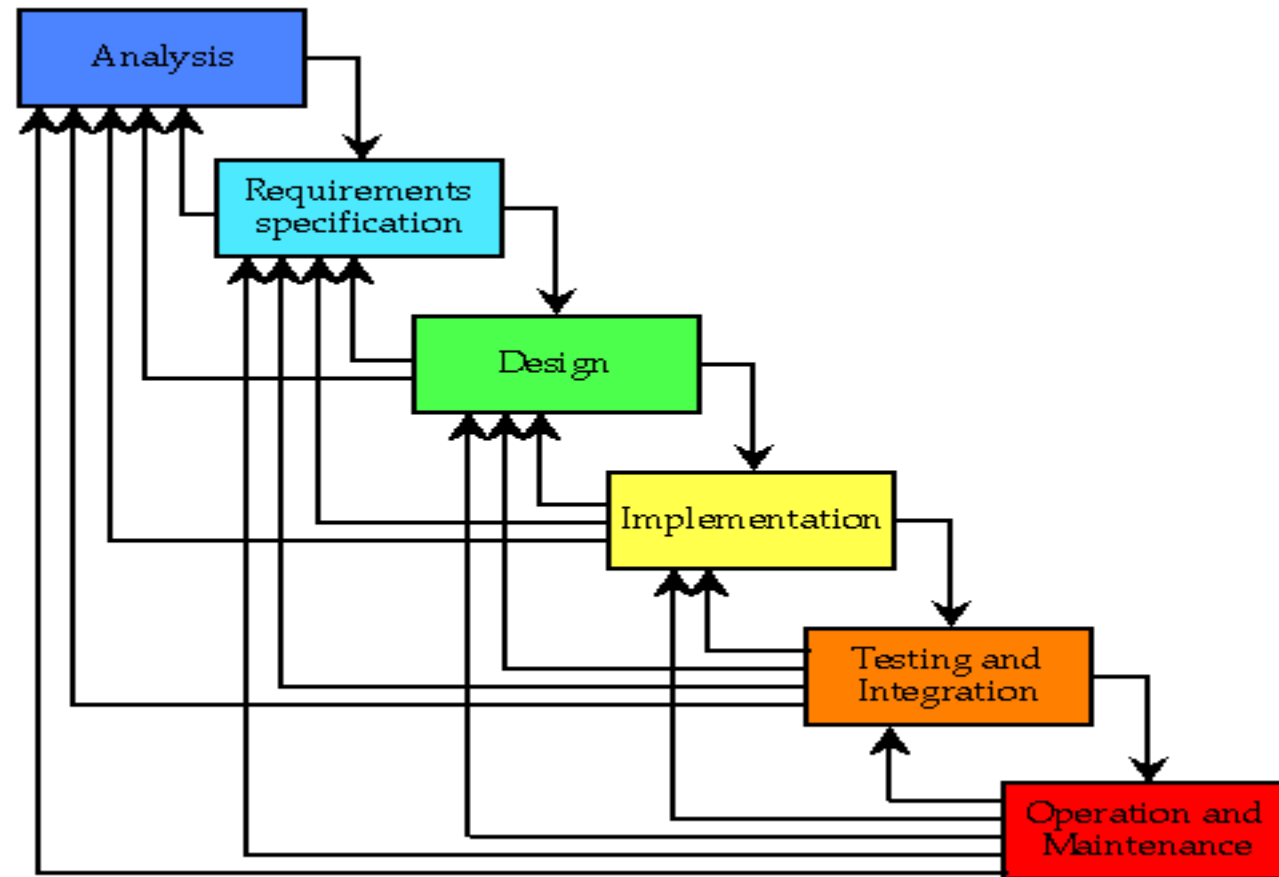

Spiral

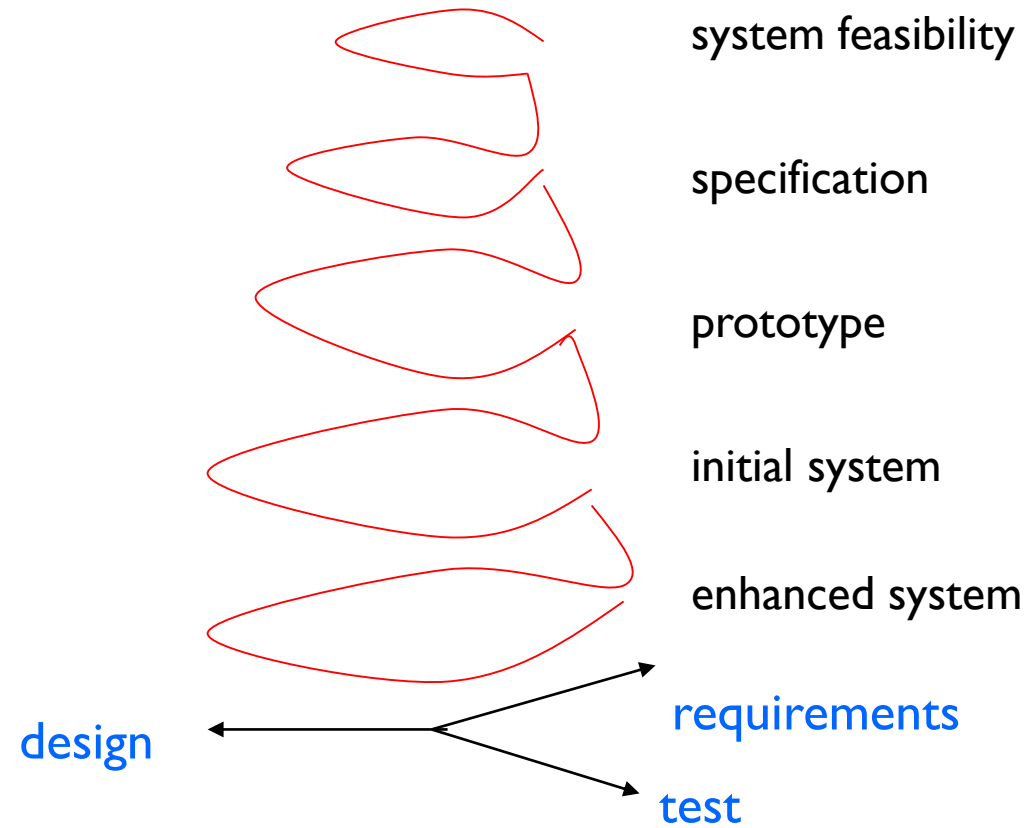

V Model Overview

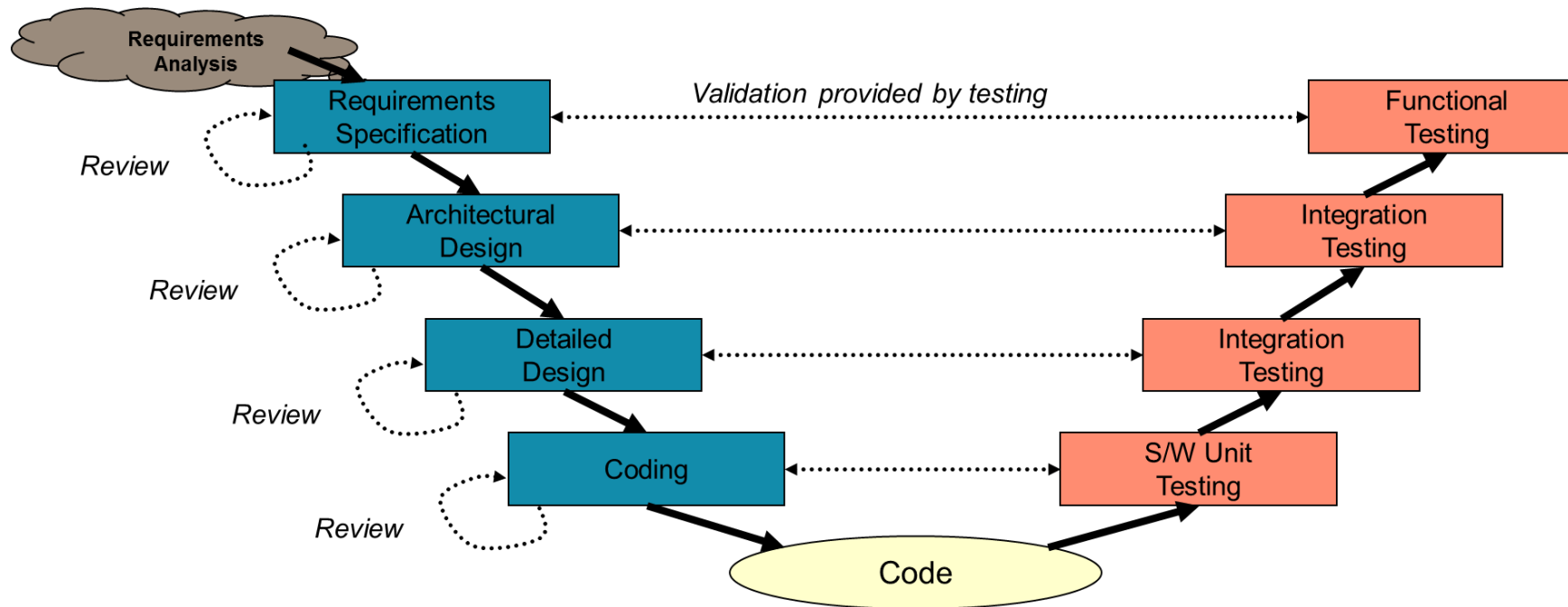

I. Requirements Specification and Validation Plan

- Should contain:
 - *Introduction* with **goals and objectives** of system
 - *Description of **problem*** to solve
 - *Functional description*
 - provides a “**processing** narrative” per function
 - lists and justifies design **constraints**
 - explains **performance** requirements
 - *Behavioral description* shows how system reacts to internal or external events and situations
 - State-based **behavior**
 - General **control flow**
 - General **data flow**
 - *Validation criteria*
 - tell us how we can decide that **a system is acceptable**. (Are we done yet?)
 - is the foundation for a **validation test plan**
 - *Bibliography and Appendix* refer to all documents related to project and provide supplementary information

Good requirements

- Correct.
- Clear. Unambiguous.
- Complete.
- Verifiable: is each requirement satisfied in the final system ?
- Consistent: requirements do not contradict each other.
- Modifiable: can update requirements easily.
- Traceable:
 - know why each requirement exists;
 - go from source documents to requirements;
 - go from requirement to implementation;
 - back from implementation to requirement.

Requirements Document

- The main purpose of a requirements document is to serve as **an agreement** between **you and your clients** describing what the system will do. This agreement can become a legally **binding contract**.
- Write the document so that it is **easy** to read and understand by others. It should be **unambiguous, complete, verifiable**, and **modifiable**.
- IEEE **templates** can be used to define a project (IEEE STD 830-1998).

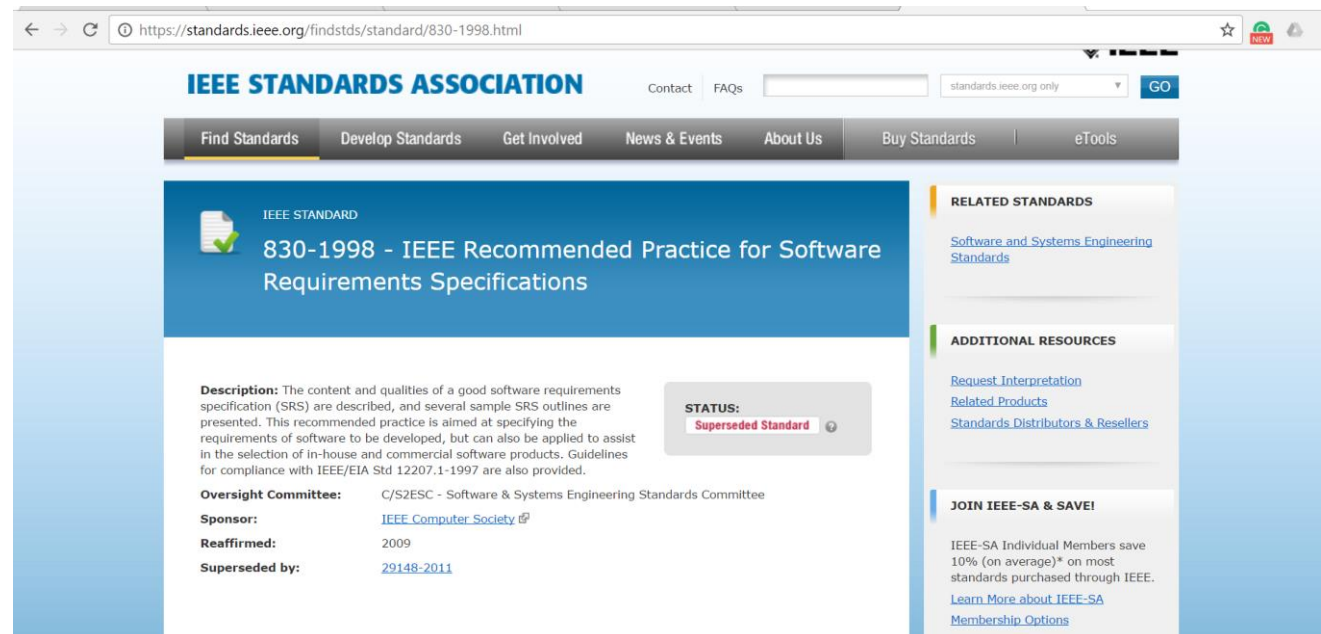

The screenshot shows the IEEE Standards Association website page for IEEE Standard 830-1998. The page title is "IEEE STANDARD 830-1998 - IEEE Recommended Practice for Software Requirements Specifications". The status is "Superseded Standard". The description states: "The content and qualities of a good software requirements specification (SRS) are described, and several sample SRS outlines are presented. This recommended practice is aimed at specifying the requirements of software to be developed, but can also be applied to assist in the selection of in-house and commercial software products. Guidelines for compliance with IEEE/EIA Std 12207.1-1997 are also provided." The oversight committee is "C/S2ESC - Software & Systems Engineering Standards Committee". The sponsor is "IEEE Computer Society". The standard was reaffirmed in 2009 and superseded by 29148-2011. The page also includes sections for "RELATED STANDARDS", "ADDITIONAL RESOURCES", and "JOIN IEEE-SA & SAVE!".

Requirements Document (cont...)

1. Overview

- 1.1. **Objectives**: Why are we doing this project? What is the purpose?
- 1.2. **Process**: How will the project be developed?
- 1.3. **Roles and Responsibilities**: Who will do what? Who are the clients?
- 1.4. **Interactions with Existing Systems**: How will it fit in?
- 1.5. **Terminology**: Define terms used in the document.
- 1.6. **Security**: How will intellectual property be managed?

2. Function Description

- 2.1. **Functionality**: What will the system do precisely?
- 2.2. **Scope**: List the phases and what will be delivered in each phase.
- 2.3. **Prototypes**: How will intermediate progress be demonstrated?
- 2.4. **Performance**: Define the measures and describe how they will be determined.

Requirements Document (Cont...)

2.5. **Usability**: Describe the interfaces. Be quantitative if possible.

2.6. **Safety**: Explain any safety requirements and how they will be measured.

3. Deliverables

3.1. **Reports**: How will the system be described?

3.2. **Audits**: How will the clients evaluate progress?

3.3. **Outcomes**: What are the deliverables? How do we know when it is done?

Types of requirements

- **Functional**
 - input/output relationships. (what the system needs to do)
- **Non-functional:**
 - Timing.
 - Power consumption,
 - Manufacturing cost.
 - Physical size.
 - Time-to-market.
 - Reliability. (emergent system behaviors)
- **Constraints**
 - what limits the design choices

2. Architectural (High-Level) Design

- Architecture defines the structure of the system
 - **Components**
 - Externally visible **properties of components**
 - **Relationships** among components
- Architecture is a representation which lets the designer...
 - **Analyze** the design's effectiveness in meeting requirements
 - Consider **alternative architectures** early
 - Reduce down-stream implementation **risks**
- Architecture matters because...
 - It's **small and simple** enough to fit into a single person's brain (as opposed to comprehending the entire program's source code)
 - It gives stakeholders a way to **describe** and therefore **discuss** the system

3. Detailed Design

- Describe aspects of how system behaves
 - Flow charts for control or data
 - State machine diagram
 - Event sequences
- Graphical representations very helpful
 - Can provide clear, single-page visualization of what system component should do
- Unified Modeling Language (UML)
 - Provides many types of diagrams
 - Some are useful for embedded system design to describe structure or behavior

State Machine for Parsing NMEA-0183

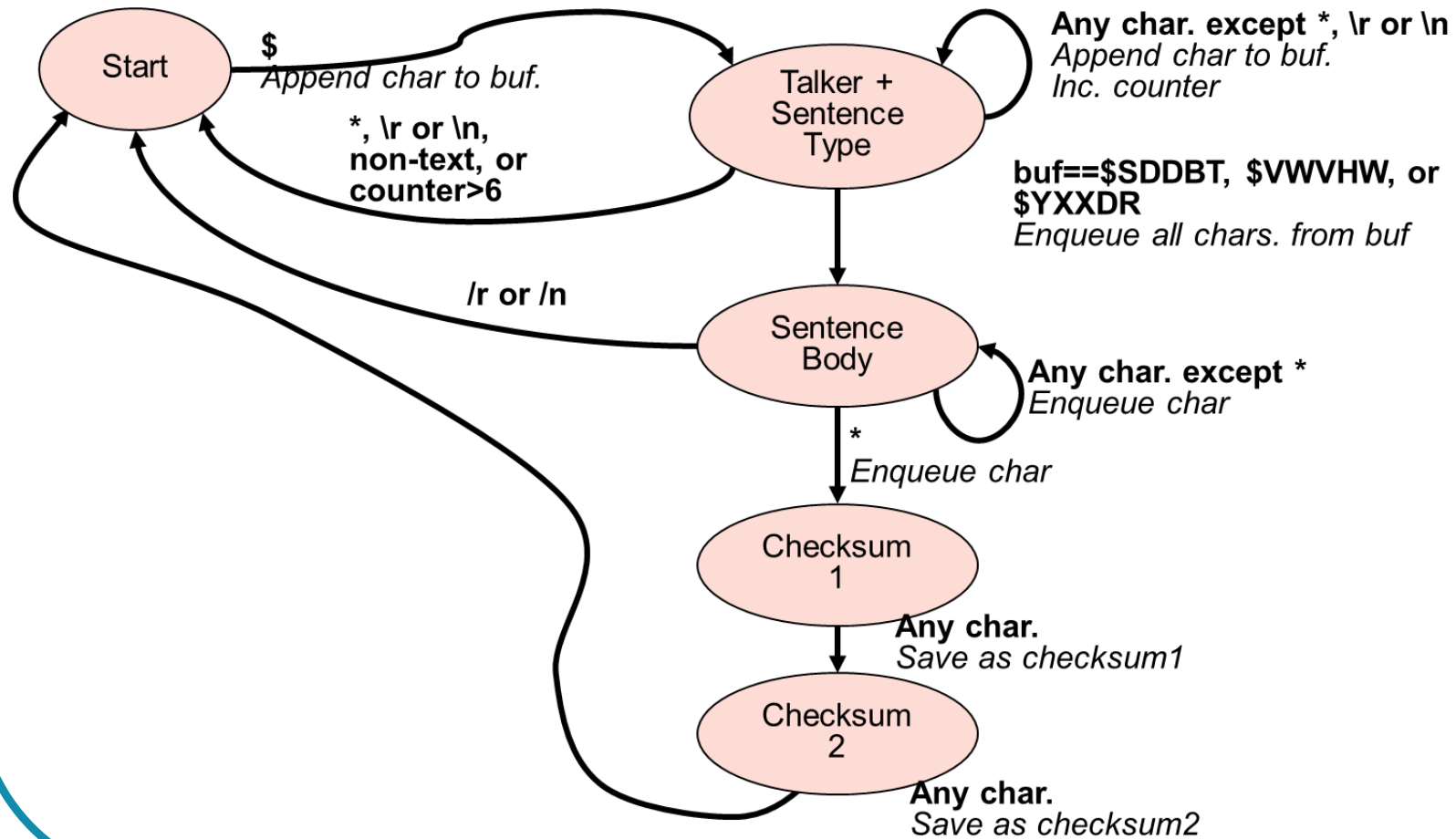

Flowcharts

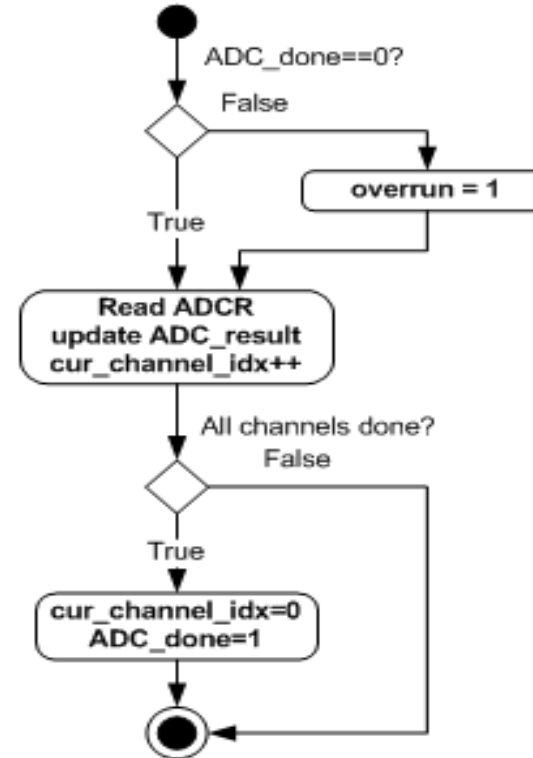
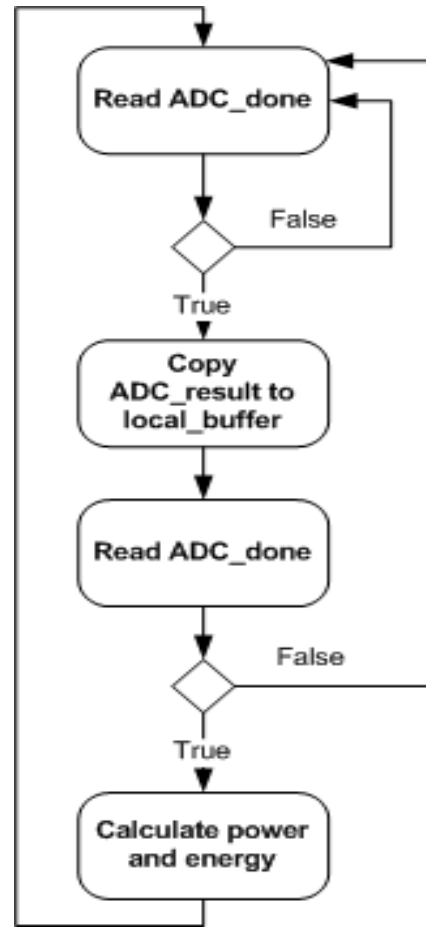

Sequence of Interactions between Components

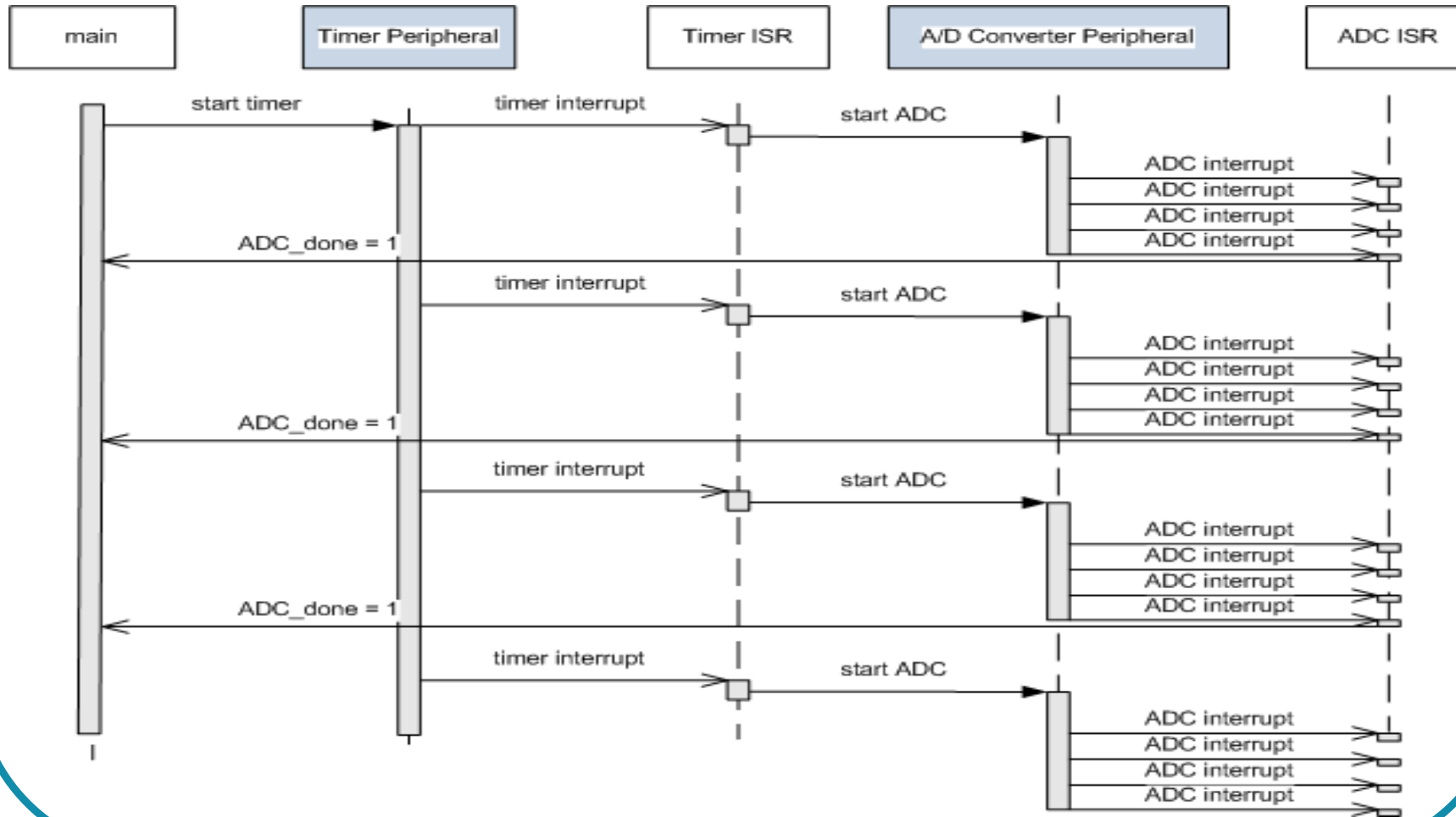

4. Coding and Code Inspections

- Coding driven **directly** by Detailed Design Specification
- Use a **version control system** while developing the code
- Follow a **coding standard**
- Perform **code reviews**
 - Peer Code Review
 - IBM removed 82% of bugs
 - 80% of the errors detected by HP's inspections were unlikely to be caught by testing
- Test effectively
 - **Automation**
 - **Regression** testing

5. Software Testing

- Testing IS NOT “the process of verifying the program works correctly”
 - The program probably won't work correctly in all possible cases
 - Professional programmers have 1-3 bugs per 100 lines of code after it is “done”
 - Testers shouldn't try to prove the program works correctly (impossible)
 - If you want and expect your program to work, you'll unconsciously miss failure because human beings are inherently biased
- The purpose of testing is to find problems quickly
 - Does the software violate the specifications?
 - Does the software violate unstated requirements?
- The purpose of finding problems is to fix the ones which matter
 - Fix the most important problems, as there isn't enough time to fix all of them
 - The *Pareto Principle* defines “the vital few, the trivial many”
 - Bugs are uneven in frequency – a vital few contribute the majority of the program failures. Fix these first.

5. Software Testing - Approaches to Testing

- Incremental Testing
 - Code a function and then test it (*module/unit/element testing*)
 - Then test a few working functions together (*integration testing*)
 - Continue enlarging the scope of tests as you write new functions
 - Incremental testing requires extra code for the *test harness*
 - A *driver* function calls the function to be tested
 - A *stub* function might be needed to simulate a function called by the function under test, and which returns or modifies data.
 - The test harness can *automate* the testing of individual functions to detect later bugs
- Big Bang Testing
 - Code up all of the functions to create the system
 - Test the complete system
 - Plug and pray

5. Software Testing - Approaches to Testing

- Incremental Testing
 - Code a function and then test it (*module/unit/element testing*)
 - Then test a few working functions together (*integration testing*)
 - Continue enlarging the scope of tests as you write new functions
 - Incremental testing requires extra code for the *test harness*
 - A *driver* function calls the function to be tested
 - A *stub* function might be needed to simulate a function called by the function under test, and which returns or modifies data.
 - The test harness can *automate* the testing of individual functions to detect later bugs
- Big Bang Testing
 - Code up all of the functions to create the system
 - Test the complete system
 - Plug and pray

Tesla Crash

[Tesla model s autopilot strikes again in dallas crash](#)

Audi A8

[..\AudiA8.mp4](#)

Assignment no. 3

kindly read the following paper [[Software Engineering for Space Exploration](#)]. In short, one paper only (2 pages), write an essay mention your opinion about the topic.

Notes:

- you will deliver your report on Sunday (at lecture time).
- you can work in a group but the group is only two students.
- you may need to read more - paper references or external resources.
- at lecture time, there will be a discussion regarding the topic, be ready to present the topic and discuss it.